

Gas Absorption Heat Pumps Will Help to Decarbonize Home Heating

Scott Reed

ABSTRACT

A new thermally driven heat pump technology on the market offers a potentially more cost-effective approach compared to 100% electrification in support of the energy transition. It economically tackles one of the toughest challenges in decarbonization—cool/cold climate building heat. With the lowest operating cost and carbon footprints in cool and cold climates, a gas absorption heat pump creates additional options for policy makers to overcome market barriers to widespread heat pump adoption and accelerate decarbonization. Energy system resiliency and reliability can be enhanced without requiring consumers to make difficult tradeoff decisions regarding cost, comfort, and convenience.

RELIABLE HEAT TO KEEP US WARM IN THE DEPTHS OF WINTER

This is an experience we often take for granted. As we advance efforts to decarbonize the economy, the methods by which heat is produced and delivered into our homes and businesses are being re-evaluated. As the people who experienced severe electric grid outages during the February 2021 cold-snap in Texas can attest, events can combine in unexpected ways to test and challenge our evolving heat-delivery systems. In North America, a diverse system of heating technologies has historically provided our winter warmth, utilizing electricity, natural gas, oil, and/or propane, depending on local resources and building owner preferences. Until we have a lot more clarity about the most effective, reliable and economic ways to decarbonize, which will likely differ regionally, it would be unwise to force people to abandon existing and proven energy systems, while leaving us only to rely on just one core method, which has yet to meet the challenge.

INTRODUCTION

Residential heating represents 43% of all energy used in the average US home [1] and is a significantly higher proportion in cool and cold climates, as well as in Canada. Current discussions on electrification assume, in the face of extensive uncertainty (discussed later in more detail), that the electrical system can technically and economically develop all the required new generation, transmission, and storage assets required of a massive new load—that of winter heating via electric heat pumps (EHPs). This is on top of other massive new electrical loads also be contemplated, such as electric vehicles (EVs), artificial intelligence (AI), and cryptocurrency. At the same time, the vision would abandon or end any further development of another existing and paid-for energy delivery system (the gas pipeline and storage network), without considering how it might be transformed for the new era, which would put our energy resiliency and security at significant risk.

Technology innovation also has a way of surprising us, and new approaches are being developed that can achieve the best of both worlds (economics and environmental progress). One example, a gas absorption heat pump (GAHP), is now manufactured in Tennessee by Stone Mountain Technologies, Inc. (SMTI) and is one of several new gas heat pumps in or entering the market. A modernized version of a cycle developed more than a century ago for making ice, GAHPs use thermal energy (heat) to drive a thermodynamic process, instead of mechanical work powered by electricity. This approach is particularly effective for heating in cold climates, as well as for large, concentrated loads (such as commercial water heating). It offers the lowest delivered cost of heating and the lowest carbon footprint—today, not at some point in the future.

The long-term success of any technology that might reduce carbon emissions ultimately depends on customers' willingness to buy and use it. For the roughly 150 million homes in North America, approximately 5 million purchase decisions are made every year regarding major heating and cooling projects. Heating, ventilating, and air conditioning (HVAC) professionals understand that consumers mainly pay attention to three major factors: comfort, cost, and convenience (the "3-Cs"). Plus, these days, a fourth "C" (climate), is gaining importance as more people also consider the environmental impacts of their choices.

THE THREE Cs

Comfort

Regardless of how much any HVAC technology costs, it must keep building occupants comfortable, or it will fail in the marketplace. For cool and cold climates (regions above 4,000 heating degree days (HDD) [$^{\circ}\text{F}\text{-day}/\text{yr}$])—where 60% of the US population and all of Canada lives—a key strength of GAHPs is providing warm air from the heat ducts in forced-air homes. They also work equally well in hydronic (boiler) heated homes.

When switching a gas-heat customer over to an all-electric solution, EHPs must be very carefully designed and commissioned to achieve a similar comfort experience. Current best-practice training for HVAC contractors doing 100% electric conversions include encouraging the customer to adjust their comfort expectations (e.g., “the air coming from your ducts will not be as warm as what you got from your old furnace”).* All-electric conversions from gas heating remain a small minority of EHP projects, and many contractors prefer jobs where (and often won’t take them unless) the gas furnace or boiler system is left in place as a backup appliance. Often these systems are configured with an outdoor temperature cross-over point where the EHP switches off, giving the heating load over to the gas-fired system. There is a tradeoff between environmental benefits, cost and comfort. At cold temperatures, EHPs become more expensive to operate and often struggle to maintain comfort. However, when the cross-over point is set to relatively mild winter temperatures (e.g., the mid-30s $^{\circ}\text{F}$) to solve this problem, environmental benefits tend to be minimized.

By contrast, GAHPs provide substantial environmental benefits, but do not require compromises to occupant comfort, and they can operate without back up or supplemental heat devices even when the outdoor temperatures are as low as -40°F (-40°C).

Cost

GAHPs generally offer the lowest cost to operate and provide heat. Figure 1 illustrates a direct comparison on an annual basis for an estimated utility cost between both types of heat pumps, as well as a traditional

*For example, see training materials offered by The US Heat Pump Summit, available at www.usheatpumpsummit.com/.

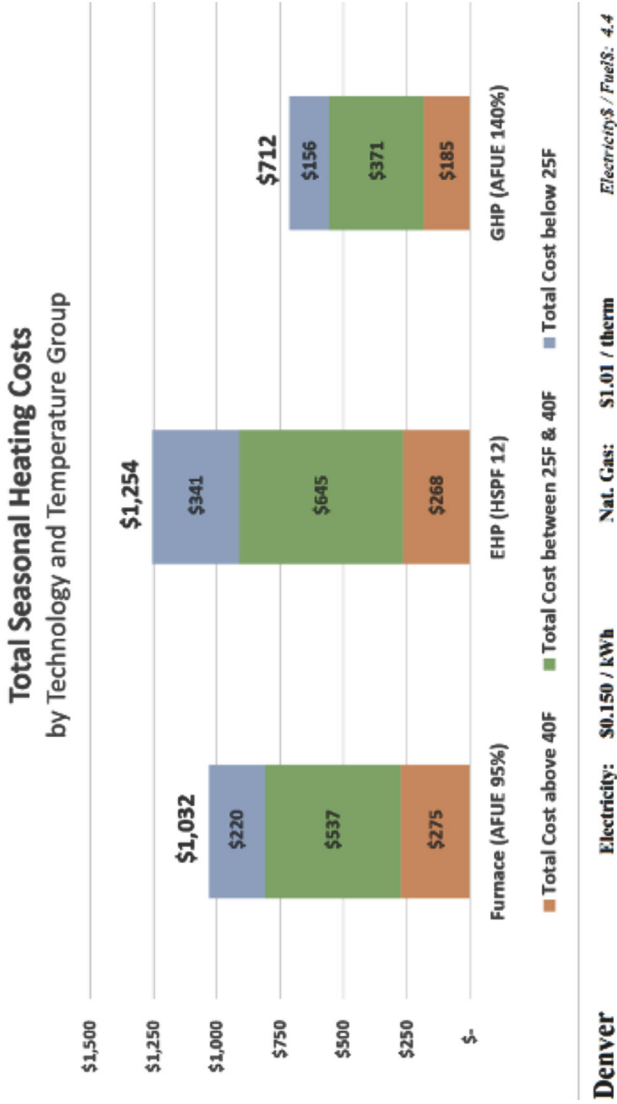

Figure 1. Operating Costs

high-efficiency gas furnace included as baseline. While the general conclusion is true across most homes, this chart is based on the model of a typical 2-story home (1,750 sq. ft.), located in Denver, Colorado. The underlying calculation methodology is discussed later in more detail.

Figure 1 also illustrates the relative impact on total operating cost as a function of outdoor ambient temperature, grouped into three major categories. Note that colder temperatures, albeit fewer total hours in the heating season, have the greatest impact on the homeowner's heating bill. An EHP, relative to the other heating methods shown in this example, is only slightly less expensive than the gas furnace in the +40°F (+4°C) and higher temperature group; but it is more expensive below that. Moreover, the GAHP is the least expensive technology to deliver heat for all temperature groups shown. Although the exact operating costs will vary by home design, climate and local energy prices, the relative comparison (the GAHP being the lowest cost to operate) generally remains true throughout North America for cool and cold climates (HDD > 4,000°F-day/yr).

Convenience

When homeowners attempt to convert their gas-heated homes over to an all-electric configuration, upgrades are often required, including to the home's electrical panel and/or the original ductwork. These upgrades can cost thousands of dollars, as well as add significant time and inconvenience to the job. Several recent news stories have been published about well-motivated homeowners trying to go "all-electric" but getting frustrated by significant and unexpected impacts to their homes and lives.* Motivated early adopters may persevere through such obstacles, but most consumers will not; a further reason why contractors often recommend leaving the existing gas heating system in place alongside the new EHP. In contrast, GAHPs can be designed to seamlessly integrate into existing home infrastructure with minimal to no modifications.

The Fourth "C"—Climate

A growing number of HVAC customers consider the climate impact in their decision making. GAHPs offer a significantly lower carbon foot-

*See for example: *Wired*. 2024. One Couple's Quest to Ditch Natural Gas. March 30, 2024. Available at <https://www.wired.com/story/home-decarbonization-solar-energy-electrification/>. Accessed December 17, 2024.

print, while EHPs may make little difference or, in some areas, increase emissions above the baseline of traditional gas appliances. The Denver example, depicted in Figure 2, can also be differentiated as to the impact of various temperature groups. Emissions from the electric grid for scenarios where the electric load is decreased or increased (such as switching from gas to electric heating), are evaluated as a function of the “last generating resource turned on” (i.e., the marginal emission factor). Again, the specific modeling assumptions are discussed later. Currently, and for many years to come, the power plants operating at the margin are fossil fuel-fired with some of the worst relative levels of energy efficiency and CO₂ emissions.

While GAHPs offer an immediate CO₂e emissions benefit using traditional natural gas, that industry is also working to decarbonize its core product—the molecules flowing through the pipelines—while retaining the inherent advantages of its pipeline network. GAHPs enhance this transition by easily switching over to future blends of carbon-neutral molecules whenever they are ready. This includes renewable biogases, hydrogen, etc. In fact, GAHPs have the effect of lowering the net cost and magnifying the environmental benefits of these new fuels, accelerating their development.

Thus, GAHPs create an immediate opportunity to reduce the consumer’s environmental footprint for building heat, while also paving the way for new and economically sound environmental benefits going into the future. With this new technology entering the market, consumers now have an additional option to help “save the planet” without making sacrifices to their own comfort, cost, or convenience.

WHY ARE EHPs MORE EXPENSIVE AND GAHPs LESS EXPENSIVE TO OPERATE?

To answer this question, let’s first start with a basic and comparative understanding of how these two heat pump cycles operate. EHPs, using the vapor compression cycle, are more commonly understood; but GAHPs, using the absorption cycle, are actually the older heat pump technology. In fact, it was the world’s first commercially successful heat pump, dating back to Ferdinand Carré’s 1859 patented invention to make ice. The cycle is driven by thermal energy—heat—instead of

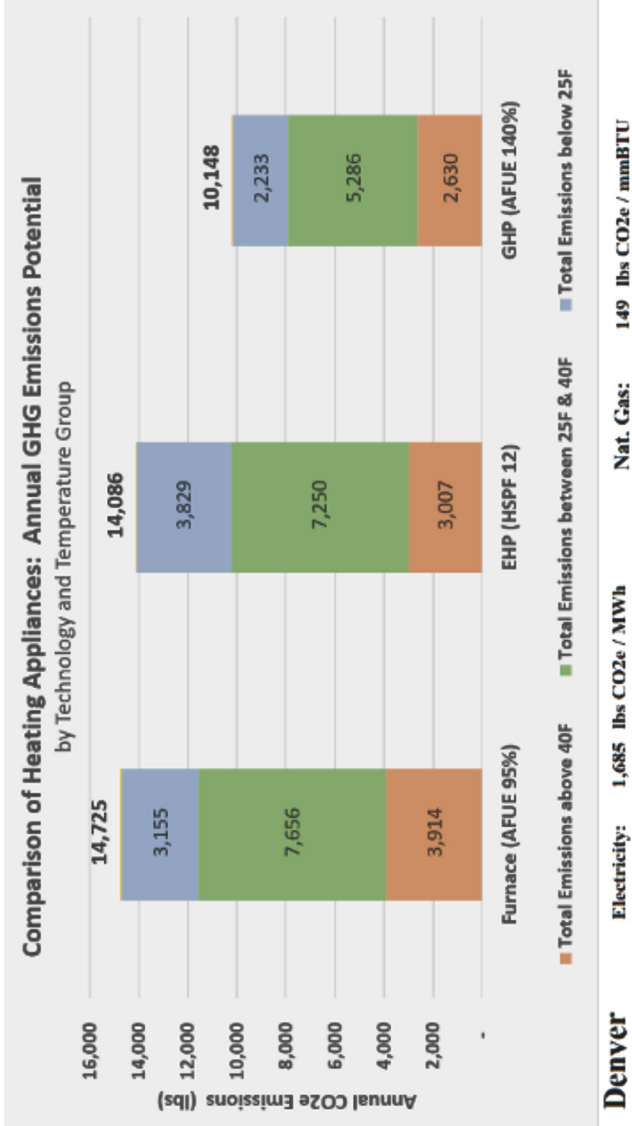

Figure 2. Carbon Footprint

mechanical work driven by electricity to operate. Heat pumps can be used for heating and/or cooling, depending on their design, and absorption held a dominant position for cooling applications (ice, refrigeration, air-conditioning) for about 100 years. However, vapor compression's superior energy efficiency for cooling eventually proved better in most cases, nearly rendering absorption a nearly forgotten technology. Nonetheless, it remains today prevalent in certain niche applications, such as the propane-drive refrigerators in RVs, and in large commercial or industrial applications utilizing waste-heat to power its cooling effect.

How Does Gas Absorption Work?

Figure 3 shows the vapor compression and absorption cycles side-by-side to illustrate their similarities and differences. While three of the four stages in each heat pump function in similar ways (condenser, evaporator and expansion device), a key difference is in the compressor. Vapor compression utilizes an electrically driven mechanical pump (compressor) to increase the pressure and temperature of the refrigerant gas before it travels to the condenser. By contrast, absorption uses heat to accomplish the same thing, by boiling a refrigerant out of an absorbent in the desorber. While other refrigerant-absorbent pairs can be used*, ammonia as the refrigerant and water as the absorbent is the most common when heating is desired. Ammonia, with the lower boiling point, vaporizes first, becoming the hot, pressurized refrigerant traveling to the condenser, while leaving the water behind. After releasing heat to the condenser (used to serve building heat load), the ammonia then decreases in pressure and temperature by flowing through the expansion valve. This sets the stage to pick up "free" energy from the outdoor air through the evaporator, allowing the GAHP to deliver more total energy to the load than the input energy consumed. Finally, the low-pressure ammonia vapor re-combines with the water in the absorber—an exothermic reaction. This generates a substantial amount of heat, which is approximately equivalent to the energy provided by the combustion of the input fuel. This heat is also captured and used as part of the net thermal output of the heat pump. Finally, the ammonia-water solution travels back to the desorber via a

*For example, lithium bromide and water.

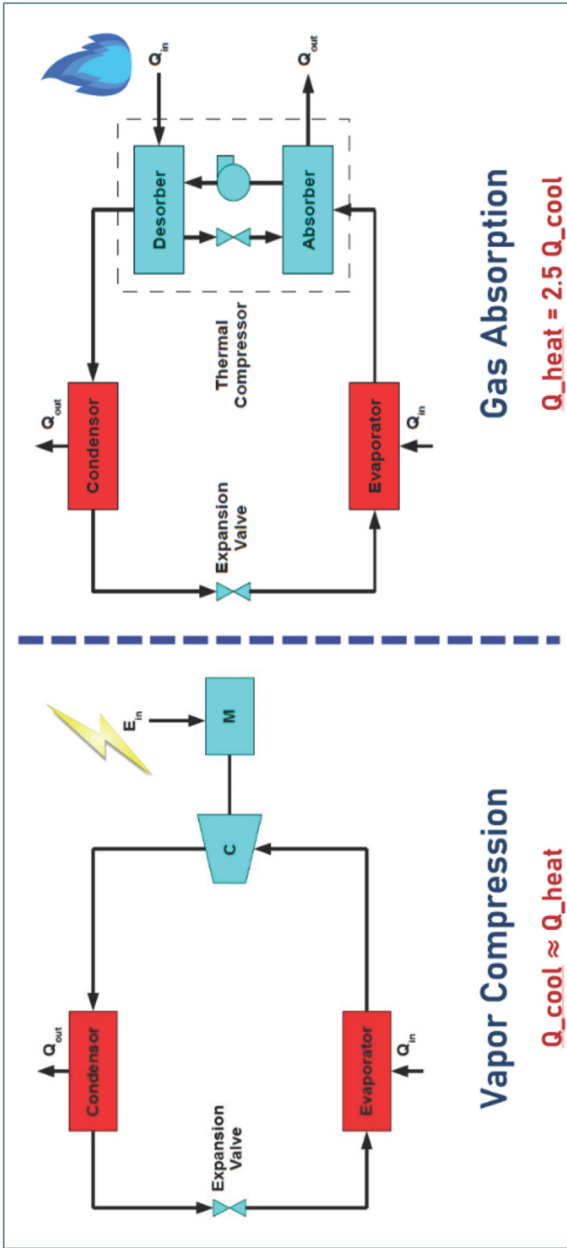

Figure 3. Comparing Vapor Compression and Gas Absorption

small solution pump, where the mixture is reheated, starting the cycle over again. The entire process can be hermetically sealed, taking place entirely within an outdoor unit. All combustion, venting, and refrigerant remain outside the building, and only a warm water + food-grade glycol mixture enters the building.

For more information examining the thermodynamics of these two heat pump cycles, please visit <https://stonemountaintechnologies.com/about/research/for> additional technical and research materials.

Vapor Compression and Absorption Performance: How Do They Compare?

Technically, both heat pump cycles can be harnessed for either or both heating and cooling. However, modern efficiency standards and economics make the absorption cycle better suited for heating, particularly in cool and cold climates. But the opposite is true for refrigeration or cooling. The typical coefficient of performance (COP) for cooling for a single-effect ammonia-water absorption cycle is approximately 0.60 at the standard rating point of 95°F. However, the heating COP is 1.45 (at 47°F), representing a significant increase compared to current conventional gas heating appliances that are limited to efficiencies below 1.00.

EHPs used for heating have been around for several decades. Historically, they have been best suited for mild-climate duties and commonly deployed in the southern US. But in the last decade, EHP designers have sought to improve their performance for cool and cold climates. A key driver for this innovation is that HVAC contractors have historically refrained from installing EHPs for cold-climate heating largely because of the complaints that they prefer to avoid from homeowners about inadequate heat and comfort as the temperature drops outside. Thus, a variation on the vapor compression cycle—the so-called “cold climate” or “inverter-driven” electric heat pump—has been created, using oversized compressors, inverters, and other innovations. However, the fundamental operation of the cycle has not changed.

As can be seen in the contrast between the red solid and dotted lines in Figure 4, modern cold-climate electric heat pumps (ccEHPs) do not lose capacity as rapidly as their older cousins when the ambient temperature drops. However, there is still a minimum point where the manufacturer requires the ccEHP to shut off. The ccEHP capacity curves shown

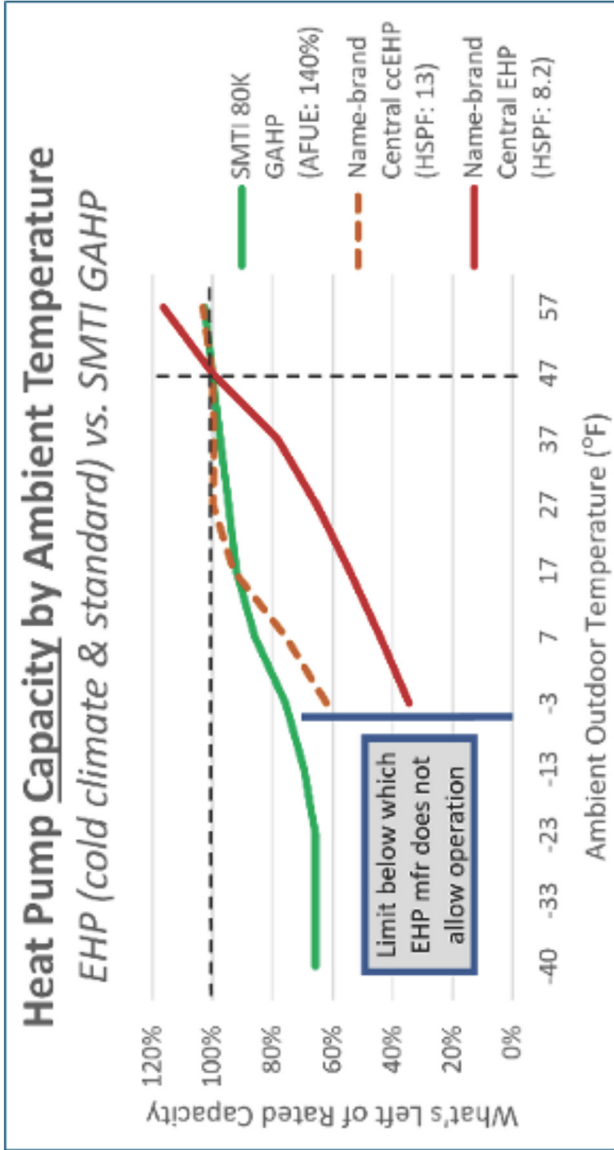

Figure 4. Performance Capacity

are existing models distributed by a well-known original equipment manufacturer (OEM), derived from their published data. For comparison, the GAHP's capacity curve (green line) displays a more robust capacity in colder weather, including the fact that it can operate in ambient temperatures as low as -40°F (-40°C), requiring no back up heat source.

There is, however, an important difference between heat pump capacity and energy efficiency. Figure 5 shows the same three heat pumps, focusing on the relative energy efficiency (as a percentage of remaining COP from the 47°F rating point) as the temperature drops. There is not much difference between the standard and cold-climate EHP models, because the thermodynamics and physics of the cycle have not materially changed.

However, the thermodynamic properties of the absorption heat pump offer significantly better energy efficiency performance as it gets colder outside.

How Do Performance Differences Translate into Operating Cost?

The COP curves in Figure 5 can be used to calculate and compare the effective cost of delivering heat for any outside temperature in which the air-source heat pump operates. Figure 6 shows the same three heat pumps and adds a traditional gas furnace (annual fuel utilization efficiency, AFUE 95%) for baseline comparison. Notably, the GAHP offers the lowest cost of delivered heat at any meaningful temperature requiring building heat. Figure 5 also demonstrates that switching gas-heated homes over to EHP-only heating has the effect of increasing their operating costs as the temperature approaches freezing outside. In mild climates, this might not matter as much; however, for cool and cold climates, this can be a significant issue.

Hourly Modeling to Estimate Operating Cost

The annual heating bill paid by the homeowner is driven by the local climate and energy prices, as well as the COP performance curve across relevant temperatures for heating. The most appropriate method to estimate performance of a heat-pump based heating technology and its impact to the homeowner's utility bill uses an hourly analysis specific to a given region. The National Renewable Energy Laboratory (NREL) publishes a widely respected building energy modeling package, Energy

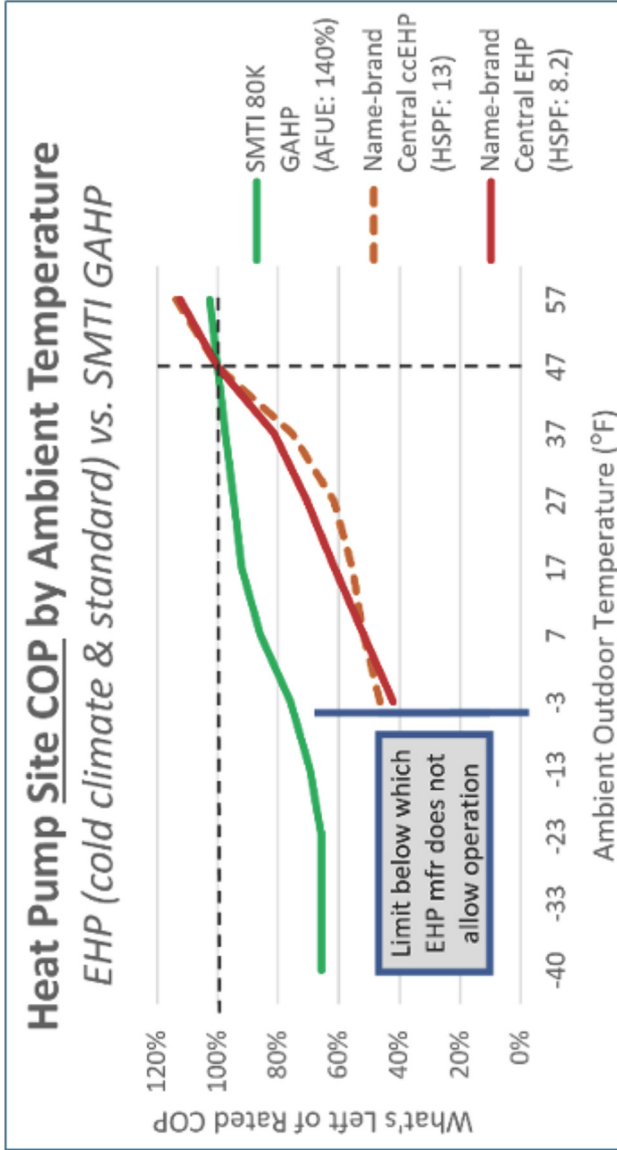

Figure 5. Performance Energy Efficiency

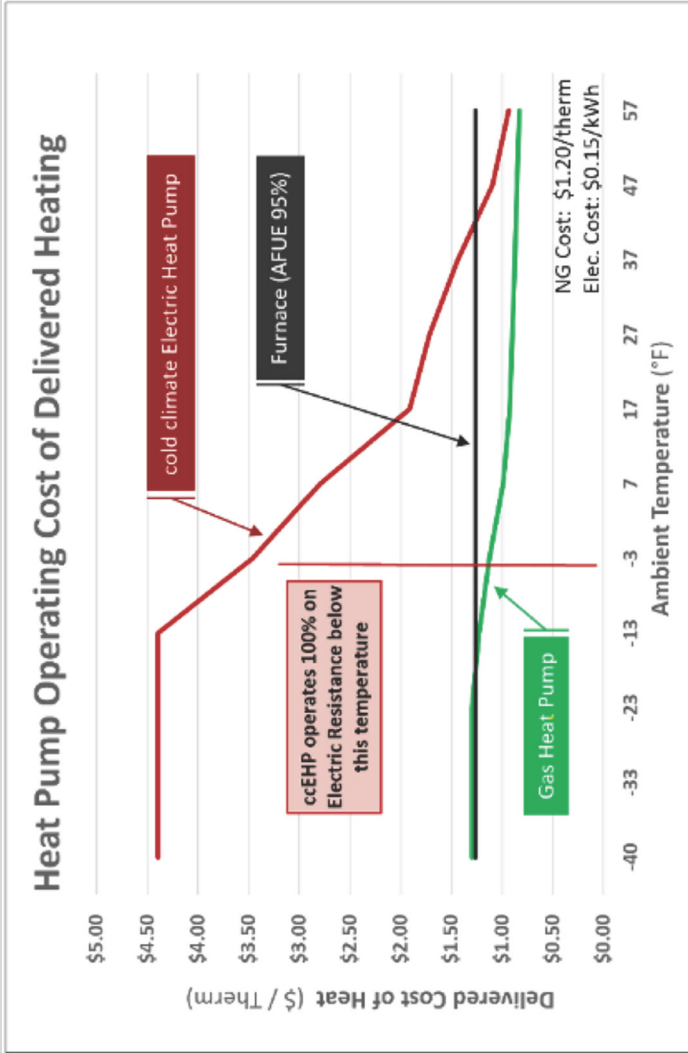

Figure 6. Cost to Operate by Temperature

(Assumes the building's heat load ranges from 60 kBtu @ -3°F to 0 kBtu @ +50°F; and the EHP uses supplemental strip heat to make up what the EHP cannot provide starting below the EHP balance point of 17°F)

Plus.* It allows the user to model a particular building design and outfit it with various levels of insulation and other measures of the envelope “tightness.” Further, the user can select different building and equipment configurations including EHPs, as well as traditional gas appliances. However, while the program’s latest version does not yet include GAHPs available as standard heating equipment, it is possible to export its hourly load data for any given building configuration and location. Since SMTI has performance curves (3rd party verified†) for its own GAHP product, it is now possible to meaningfully and directly compare the performance for both types of heat pumps for many building types and climates. Given the current debate about heating technologies, it is relevant to make reasonable annual estimates for both EHPs and GAHPs regarding total cost of operation, as well as their greenhouse gas (GHG) footprints. This approach is what generated the charts in Figures 1 and 2.

Operating Cost of Delivered Heat

A more nuanced view on operating cost is found in Figure 7, modeling the impact to homeowner utility costs but separated into 5°F temperature bands and showing more precisely where the costs are concentrated. The overall analysis includes parasitic power for all devices. For Denver’s most common temperatures during the heating season, the cost advantages and disadvantages of each technology are clearly visible.

Performing this type of analysis across a variety of cool/cold climate regions in North America shows generally that GAHPs offer the lowest cost of delivered heat in most areas. The combination of various climates and local energy prices result in the ccEHP option to be relatively more or less costly than the AFUE 95% gas furnace depicted in the Denver example. However, across a wide range of North American regions (HDD > 4,000°F-day/yr), the GAHP invariably comes out as the lowest total heating bill to the homeowner. See Appendix A at the end of this article for a larger sample.

*EnergyPlus (<https://energyplus.net/>) is most accessible via the user-friendly interface. Building Energy Optimization Tool (BEOpt™) software, available through NREL, provides capabilities to evaluate residential building designs and identify cost-optimal efficiency packages at various levels of whole-house energy savings along the path to zero net energy. Available at <https://www.nrel.gov/buildings/beopt.html/>.

†Verified by GTI Energy.

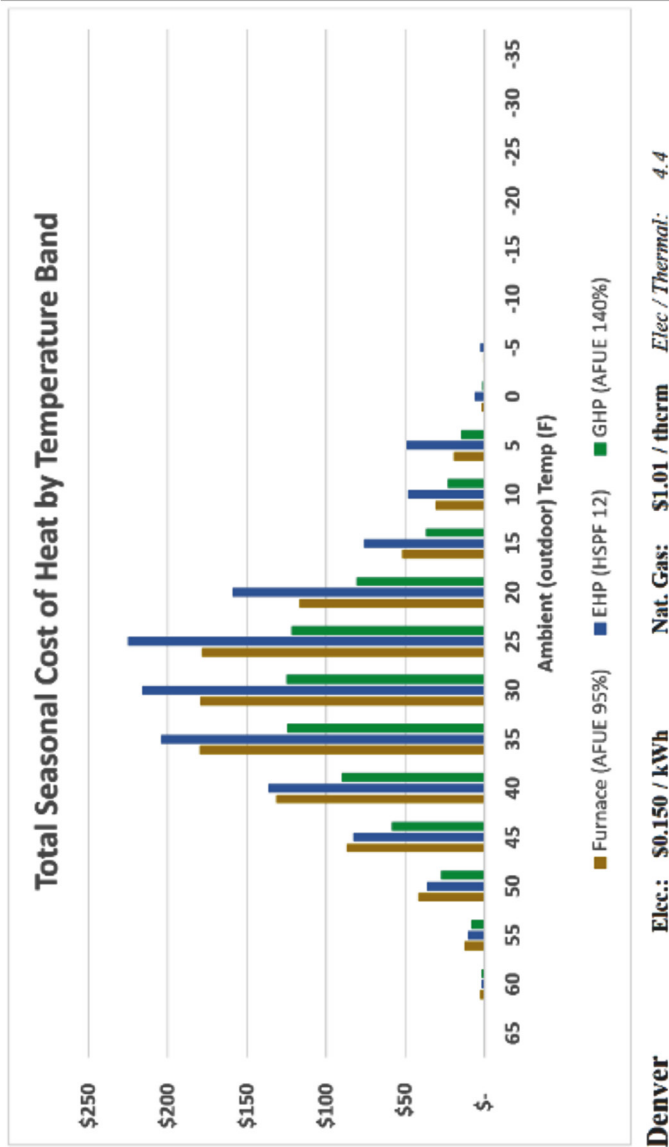

Figure 7. Cost of Delivered Heat by Temperature Band

Life Cycle Cost of Heating

In the Denver example*, there is more than \$500 per year in the operating cost difference between GAHPs and EHPs. Assuming a 20-year product life cycle, the GAHP would have a \$10,000 total cost advantage over the EHP on operating cost alone. Installation costs will vary depending on the home's configuration; however, it is reasonable to assume that both types of heat pumps will have roughly similar installation costs. Thus, the total lifecycle cost of GAHPs and their levelized cost of heat delivered into the home will most likely be significantly lower than EHPs.

Marketplace discussions for EHP economics tend to focus on their higher installation costs, and this is what current incentive programs usually try to offset. However, the impact of a larger annual heating bill for the homeowner needs discussion because it is primarily what drives total life cycle cost. This raises questions for policymakers regarding the most economically efficient use of public incentive dollars.

HOW DO EHPs AND GHPs COMPARE ON GHG EMISSIONS?

Given that actual energy used is one of the hourly model's outputs, an approach similar to calculating operating cost can be undertaken to estimate comparative GHG emissions levels for each heating technology. Annual GHG emission profiles for the Denver example were previously shown in Figure 2.

For natural gas, the full value-chain impact is used (149 lbs/million Btu*) to account for all CO₂e from “well-head to burner-tip”; it is not limited to just the point of combustion. While for Denver, the EHP shows a slight improvement in the GHG footprint (relative to the gas furnace baseline), the GAHP demonstrates the best GHG reduction benefit. Again, the GAHP reveals its greatest strength in colder temperatures.

For electricity, the assumption is taken from the US EPA's eGrid emissions data (2022) for the subregion that includes Denver; specifically, the “non-baseload emission rate” factor (i.e., the marginal resource)

*Energy prices are based on residential tariffs charged by Xcel Energy—Colorado.

†Informed by GTI Energy's Energy Planning and Analysis Tool (EPAT).

which is appropriate for a fuel-switching scenario, versus the “total output emission rate” (i.e., the average resource). It is generally agreed in the energy efficiency community that using counting marginal emissions is the most appropriate method for energy saving and fuel-switching types of projects; and eGrid has historically been the most widely cited source.

Denver’s grid still has a lot of coal in the mix, but what about relatively “cleaner” grids? This topic is the subject of some debate. The “marginal” carbon content of the grid remains the most appropriate to use, but eGrid’s “non-baseline” metric does not account for the way that electric utilities buy power in the marketplace on a day-to-day and hour-to-hour basis. As pointed out in a recent ASHRAE Journal article [2], this process creates a purchasing “load order”—essentially a continuous buyer’s auction—that generally leaves simple-cycle natural gas peaker generation plants as the last or marginal resource. These plants’ carbon footprint is typically about 1,500 lbs per MWh generated. SMTT’s modeling uses somewhere between this and the region’s particular eGrid “non-baseline” rate as the assumption for any region’s electric grid CO₂e factor. Appendix B at the end of this article contains a broader regional sample of comparisons.

THINKING ABOUT THE FUTURE

“Even if GAHPs are less expensive to operate, and they reduce carbon emissions more than EHPs today, what about the idea that the electric grid will eventually clean up and EHPs will then be the ‘cleaner’ technology. So, shouldn’t we just stop investing in the gas system now, so we can prepare for that change?”

—An argument sometimes posed by advocates
of 100% electrification.*

The “all-electric/all-now” argument for winter heating presumes, to a very large degree, to know how the energy transition will play out. It assumes over the next couple of decades or so that massive amounts of zero-carbon electricity will be generated, delivered, and distributed without fail by a single energy system into tens of millions of people’s

*Undocumented source.

homes, during the winter heating season. Clearly some level of electrification is likely to, and probably should, happen. But several credible research organizations, looking at the large-scale, economy-wide issues unfolding out as far as 2050, express a lot more uncertainty than certainty about the precise pathway and the exact mix of renewable resources.

NREL's scenarios for *100% Clean Electricity by 2035* [3], published in 2022, generally require wind generation to increase about seven-times above its present 3750 TWh level; and solar to scale up by 20-times above 2020's 100 TWh output. Massive energy storage to firm up these intermittent resources for wintertime heating loads does not yet technically, much less economically, exist. Getting all that power to end-users will also require an unprecedented and aggressive transmission-building plan, and it must overcome the expected plethora of NIMBY (not in my back yard) issues. On average, NREL finds that the grid needs to be built out at least 2 to 3 times its existing capacity for the US. However, that ratio will be even higher for colder climates.

The *Low Carbon Resource Initiative* (a joint project operated by Electric Power Resource Institute (EPRI) and GTI Energy) recently created an economy-wide model to examine prospects for complete decarbonization by 2050 [4]. Among their findings included the high uncertainty in how the transition will play out. They also noted that maximizing technology and energy options enables affordability. Specifically, gas pipelines will continue to play a critical role both in using gas for firming the grid as renewables increase, as well as for delivering low/zero-carbon fuels in the future for both industries and buildings.

GTI Energy, in a separate "*meta-analysis*" of *five economy-wide net-zero energy decarbonization studies*, found a wide range of predicted levels of various forms of renewable energy and concluded that no one yet has all the answers. [5] However, they also concluded that the gas and liquid fuels grids need to be maintained.

The point here is not to say all this cannot be done, but instead, it is to note just how much uncertainty remains, both for exactly how it plays out, as well as the timelines. Adding to this, no one has really anticipated the innovation of new GAHP products that have robust, economically valuable, and environmentally useful cold-climate heating characteristics.

The Gas System is Also Cleaning Up

The electric grid only began its “cleaner-electron” agenda in earnest in the 2000s and started to accelerate in the 2010s. It still has a long way to go. Similarly, the gas industry is recognizing that its core product—the molecules delivered via pipelines (presently ground-sourced CH₄)—cannot ultimately remain the same and must fundamentally change. That process will also take some time, but the pace of change is starting to accelerate. Some utilities already offer a net-zero carbon gas option to their customers*. Others are investing heavily in “green” hydrogen and/or “renewable natural gas”—either of which can have minimal or zero environmental impact. In some cases, they may even offer a “clean-up” benefit, by taking carbon dioxide from the atmosphere on a net basis. The gas industry, like the electric industry, is seeing that it faces an existential moment and must change. GAHPs, because they use a lot less gas, function as an economic accelerant to changing the molecules by making their net cost to society a lot lower, while enhancing their emissions reduction benefit. The technology is part of a developing alternative approach that contrasts with making large economically questionable investments in massive new electric generation and power distribution, when the currently existing pipeline network could suffice with different content.

Let’s Keep Our Options Open

In the face of all this technical, economic, and political uncertainty, as well as the likely preferences of the non-early-adopter marketplace, it may be unwise for utility regulators and other policymakers to simply push the gas system towards the exits. With GAHPs now on the market today, a consumer can make an environmentally responsible choice, stay comfortable during the winter, and save themselves significant expenses in the family budget. Additionally, government usually functions at its best when it sets broad outcome goals and then lets the market sort through the risks and rewards to determine the winners. Further, it is generally better to create options for solving complex problems, rather than to cut them off. Regulatory support to develop and support GAHP (re)entrance to the market would be wise, allowing true market competition to take place.

*For example, see FortisBC, British Columbia, available at <https://www.fortisbc.com/>.

References

- [1] US Energy Information Administration (EIA). 2023. Use of Energy Explained: Energy Use in Homes. EIA, Washington DC. Available at <https://www.eia.gov/energyexplained/use-of-energy/homes.php>. Accessed December 17, 2023.
- [2] Ryan, W. 2024. Understanding Marginal Carbon Factors and Why They Matter. *ASHRAE Journal*. Atlanta, GA. January 2024.
- [3] NREL. 2022. Energy Analysis. 100% Clean Electricity by 2035 Study. Available at <https://www.nrel.gov/analysis/100-percent-clean-electricity-by-2035-study.html>. Accessed December 17, 2023.
- [4] EPRI. 2024. Low-Carbon Resources Initiative. Available at <https://www.epri.com/research/sectors/lcri>. Accessed December 17, 2024.
- [5] GTI Energy. 2024. Designs for Net-Zero Energy Systems: Meta-Analysis of U.S. Economy-Wide Decarbonization Studies. Available at <https://www.gti.energy/meta-nz/>. Accessed December 17, 2024.



AUTHOR BIOGRAPHY

Scott Reed is a vice president at Stone Mountain Technologies, Inc. (SMTI), the manufacturer of Anesi Gas Heat Pumps (www.AnesiComfort.com), where he is responsible for the regulatory and business development sides of the company. SMTI was started in 2010 with an initial grant from the US Department of Energy to develop and test gas heat pump water heaters, and the company grew from there. Since then, with more than \$35 million in grants and investment, the company has developed and tested a wide range of gas heat pumps and related products, and it launched manufacturing in Tennessee in 2024. Mr. Reed joined SMTI in 2015 following his previous career in the solar industry. He holds CEM and CMVP certifications from the Association of Energy Engineers (AEE), as well as an MBA from the University of Southern California. Scott Reed may be contacted at SReed@AnesiComfort.com.

APPENDIX A OPERATING COSTS ACROSS THE LANDSCAPE

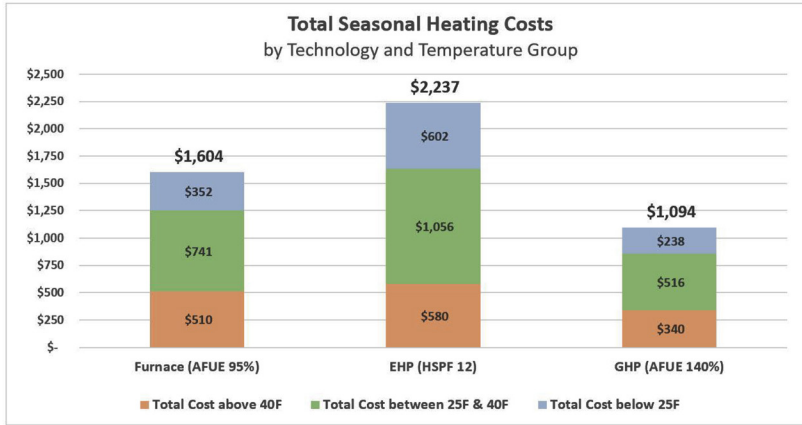

Boston

Electricity: \$0.33 / kWh Gas: \$1.80 / therm Elec/NG Ratio: 5.33

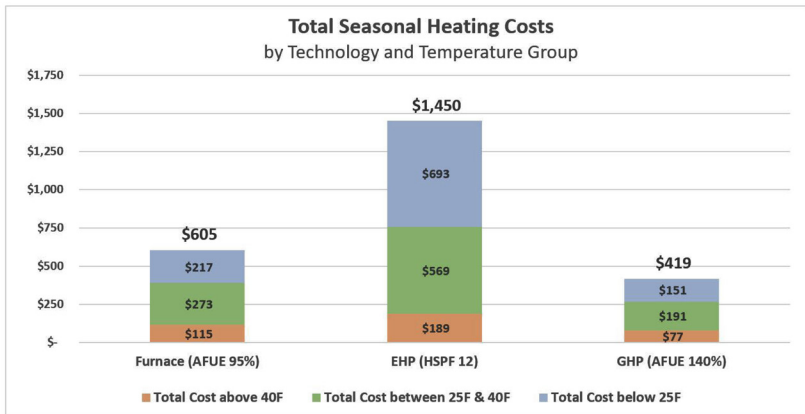

Chicago

Electricity: \$0.17 / kWh Gas: \$0.58 / therm Elec/NG Ratio: 8.54

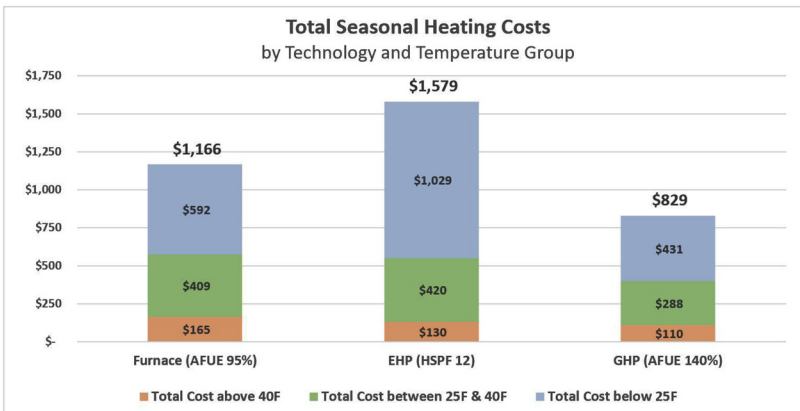

Minneapolis

Electricity: \$0.15 / kWh Gas: \$1.27 / therm Elec/NG Ratio: 3.48

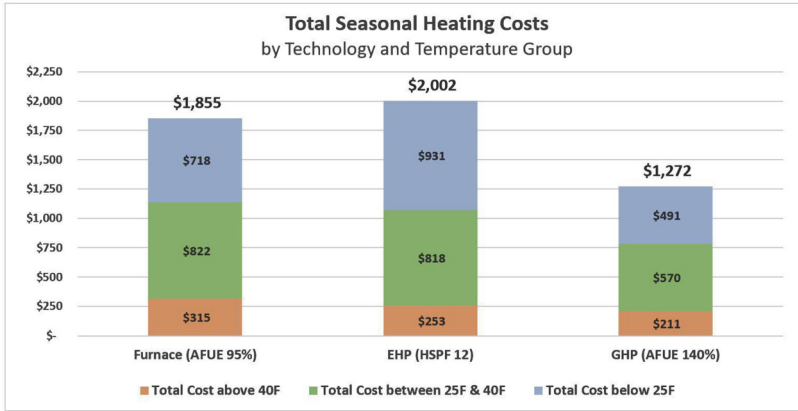

Toronto

Electricity: \$0.19 / kWh Gas: \$1.56 / therm Elec/NG Ratio: 3.50

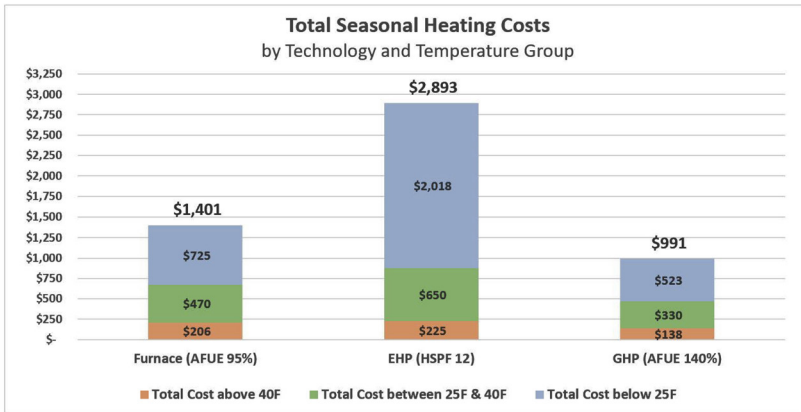

Calgary

Electricity: \$0.20 / kWh Gas: \$1.17 / therm Elec/NG Ratio: 5.00

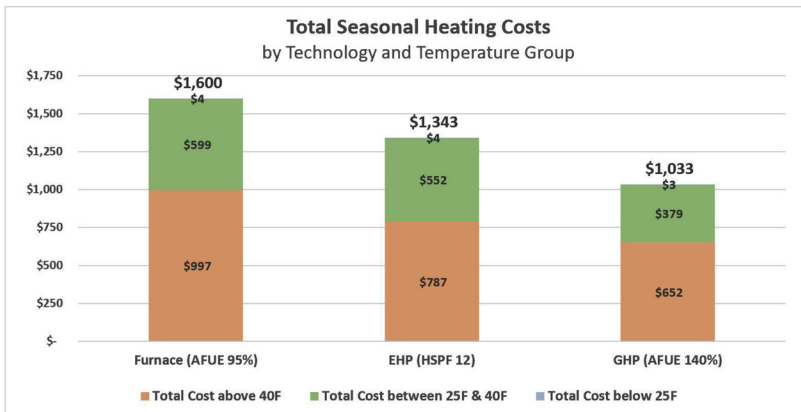

Vancouver

Electricity: \$0.14 / kWh Gas: \$1.14 / therm Elec/NG Ratio: 3.64

APPENDIX B CARBON FOOTPRINTS ACROSS THE LANDSCAPE

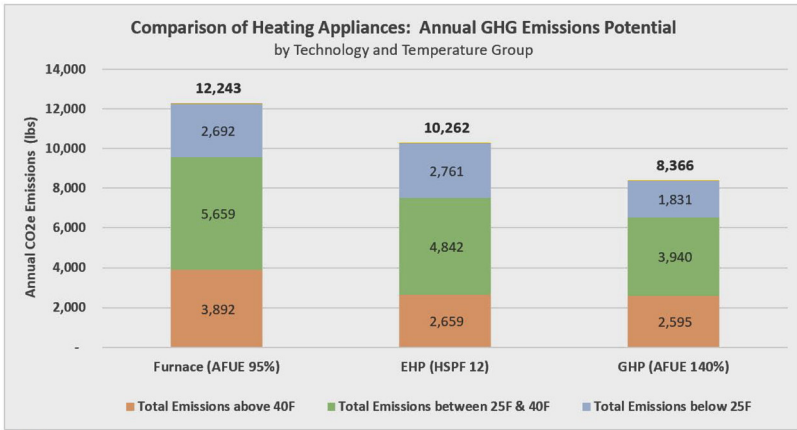

Boston

Electricity: 1,500 lbs CO₂e / MWh

Natural Gas: 149 lbs CO₂e / mmBTU

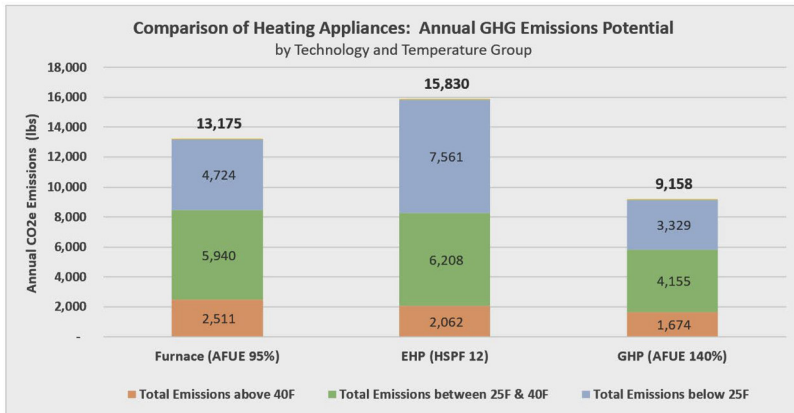

Chicago

Electricity: 1,856 lbs CO₂e / MWh

Natural Gas: 149 lbs CO₂e / mmBTU

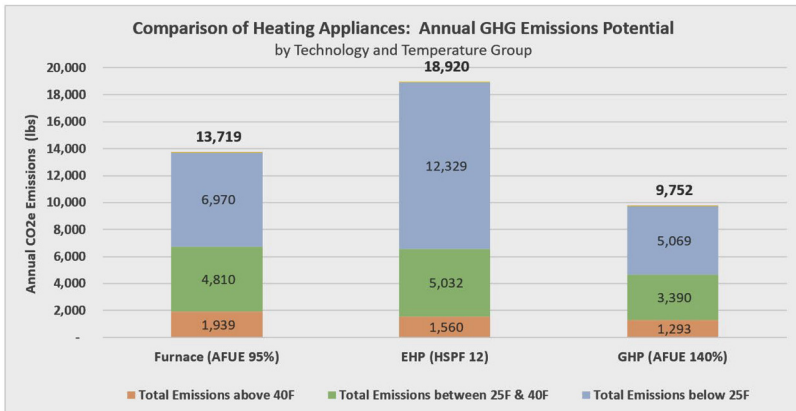

Minneapolis

Electricity: 1,807 lbs CO₂e / MWh

Natural Gas: 149 lbs CO₂e / mmBTU

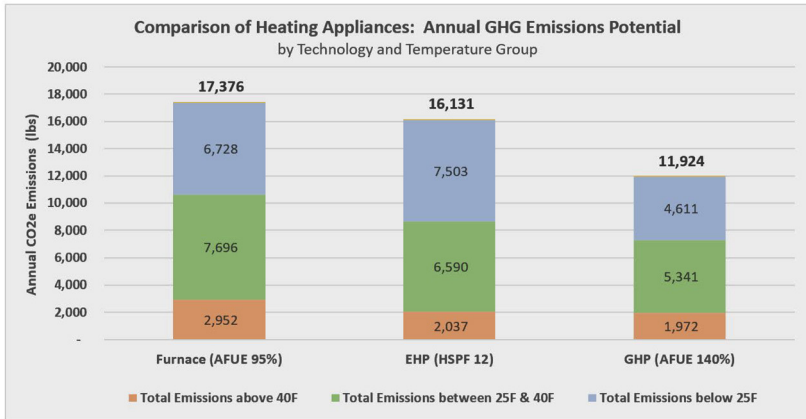

Toronto

Electricity: 1,500 lbs CO₂e / MWh

Natural Gas: 149 lbs CO₂e / mmBTU

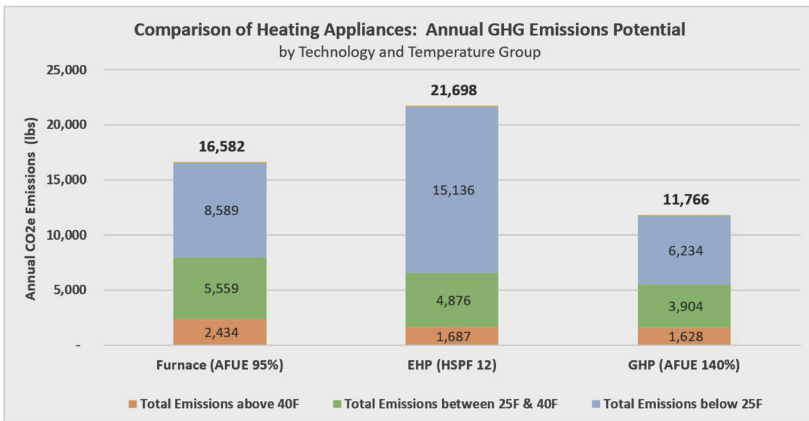

Calgary

Electricity: 1,500 lbs CO₂e / MWh

Natural Gas: 149 lbs CO₂e / mmBTU

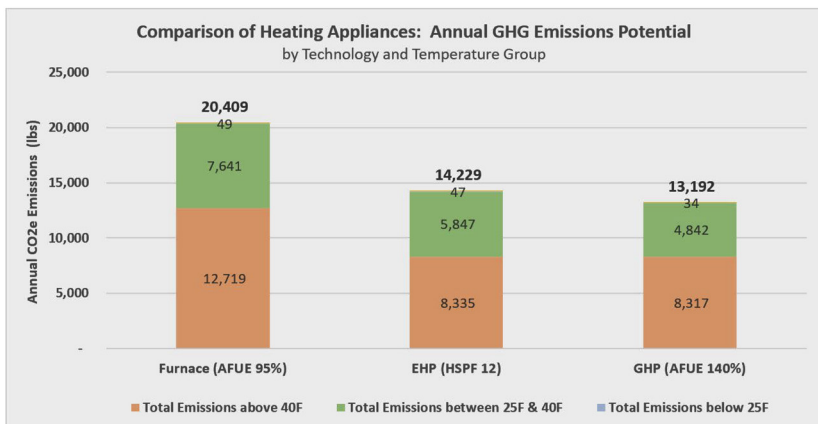

Vancouver

Electricity: 1,500 lbs CO₂e / MWh

Natural Gas: 149 lbs CO₂e / mmBTU